



LIGATURE RESISTANT SENSOR FAUCET

#SF400

PATENT # US D635,386

Installation, Maintenance & Operation Instructions

Our patented Sensor Faucet has now been improved with the introduction of the new #SF400 model! The new model features a new and improved sensor module design with updated operating mechanisms including the electronic module, solenoid, and power pack and comes with standard in-line filters. The new model still has the same sloped and rounded profile as the previous model, keeping the design ligature resistant. The touchless activation is ADA compliant and helps with infection control. The faucet is easily installed in new construction and retrofit applications. Battery power is standard, and an AC adapter is optionally available. The all metal exterior has a chrome-plated finish which is optimal for vandal resistance and aesthetic appearance.



Specifications

- Fits both a standard 4" centerset and an 8" center set sink with our optional conversion kit assembly
- Updated operating mechanisms (Electronic module, Solenoid and Power Pack) which are readily serviceable from under the counter
- Standard in-line Filters, and new Sensor Module design
- Available in either standard battery (six 1.5v AA batteries) or optional AC power
- Programmed vandal protection maximum run time of 60 seconds
- Includes a 1.2 GPM (4.5 L/min) flow rate hygienic laminar flow outlet
- Includes an under counter mechanical mixer with check valves for cross flow protection
- Inlet Supply: 3/8" compression with male threads for already mixed Cold and Hot Water
- Can be optionally fitted with an ASME 1070 thermostatic valve
- This faucet has an operating range of 20-80psi
- Pre-assembled for simple installation
- All metal housing designed for maximum strength and protection from abuse with a polished chrome finish

Certifications

- ADA compliant
- This product is certified by IAPMO to meet UPC · ASME A112.18.1/CSA B125· NSF 372 · AB 1953 California and National low-lead requirements
- **Gold Seal of Approval** - NYS Office of Mental Health Patient Safety Standards, Materials and Systems Guidelines



Standard Features

- The Faucet comes with a rubber gasket to seat it on the sink.
- The Central shank can be connected directly to the solenoid or a flex hose (included) if more room is needed.
- Laminar Flow 1.2 GPM flow control outlet
- Under Counter Mixer Tee with check valves and flex hose connection to the solenoid box.
- Internal Battery Pack includes six 1.5v AA batteries

Options *(see accessories on besafepro.com)*

- A/C Adapter Kit (RPG76-107259)
- Under Counter Thermostatic Lead-Free Valve with Check Valves (SF372)
- 8" Cover Plate (SF373) — Converts 8" Centerset Sink to 4" on center

Care & Cleaning

Your new Product is designed for years of trouble-free performance. Keep it looking new by cleaning it periodically with a soft cloth. The use of harsh chemicals and abrasives on any of the custom finish products may damage the finish and void the product warranty. Please be sure to only use approved cleaners.

Waiver & Disclaimer

This waiver-disclaimer is attached to and made a part of the written contract to purchase these products for use in psychiatric and correctional facilities. Such fixtures and products are purchased to reduce the risk of self-imposed death or injury to patients or clients in such facilities, but are NOT represented as able to prevent such death or injury.

Behavioral Safety Products, LLC ("BSP") as the seller and Speakman Company as the manufacturer of these products have not, and will not represent or warrant to the purchaser shown in this contract ("Purchaser") that its fixtures and products will prevent death or injury in any case whatsoever.

BSP and Speakman Company make no express or implied warranty with respect to the preventative quality of its products, but merely represents that the use of such products tends to reduce deaths and injuries by patients or clients who are subject to meticulous screening processes and diligent supervision on the part of the facility housing them.

Purchaser acknowledges the foregoing disclaimer and waives any and all claims against BSP and Speakman Company as to express or implied warranties of fitness for any purpose whatsoever.

IMPORTANT

- This fixture must be mounted with its back to a wall.
- It is unsafe if the unit could be accessed from the back side.
- All plumbing and electrical connections under the sink are not ligature resistant and should be in a separate enclosure or cabinet (not supplied).

Rough In Dimensions

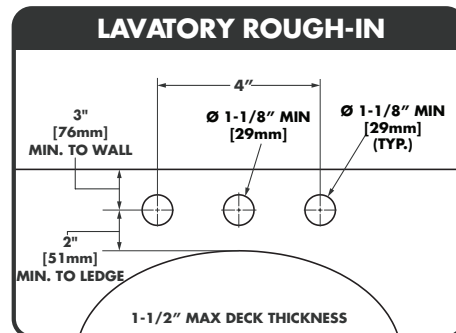
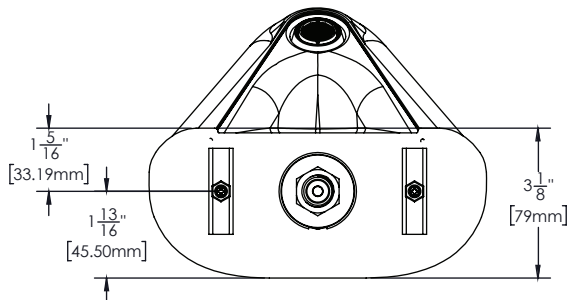
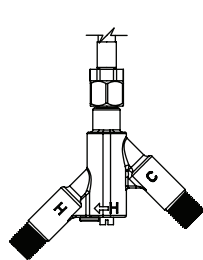
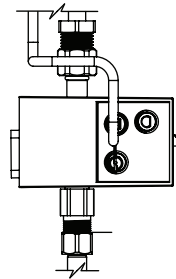
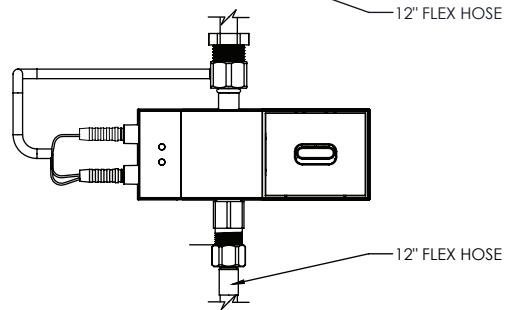
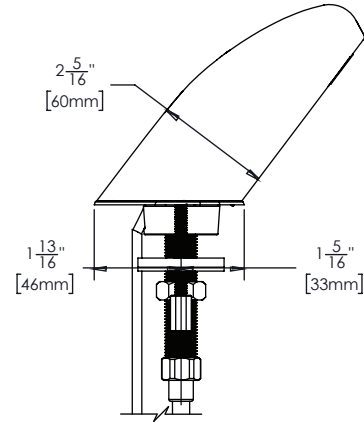
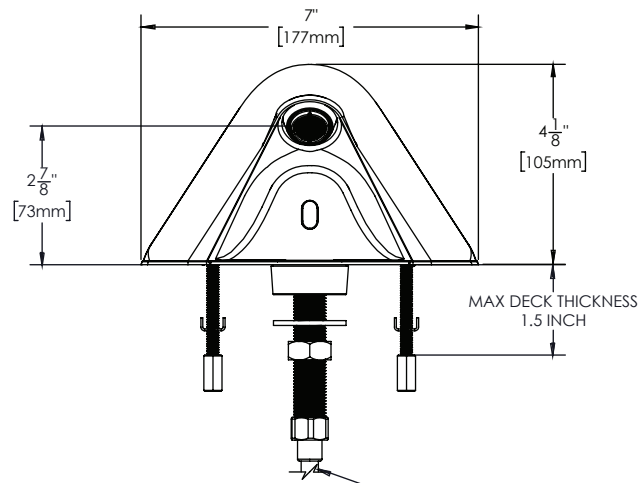

IMPORTANT

- Be sure to read instructions thoroughly before beginning installation.
- Do not over-tighten any connections or damage may occur.

Tools and Supplies

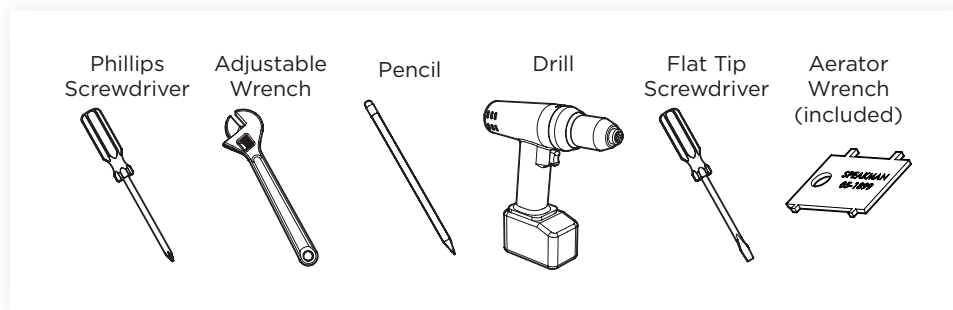

Installation Instructions

1. A sink top with 4" on center holes (outer hole centerline to outer hole centerline) is required for proper installation. Ensure that there is a minimum of 3" from the centerline of the holes to the back wall or back of sink. Remove Screws, and Protective Cover from Valve. Set aside for future use.

NOTE

Faucet is designed to be installed on a DECK with a flat surface. Optional 8" Cover Plate (SF373) is available. See "OPTIONS" section on Page 2

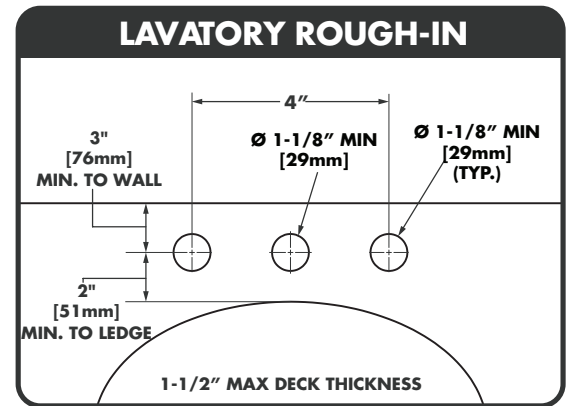

2. Install Threaded Mounting Posts (1) to Faucet body and tighten with Phillips Head Screwdriver. Insert the wire connections through the center hole in mounting surface, followed by the Faucet Shank. Take extra precautions to avoid pinching any wires. Once Faucet is positioned, verify that the rear of Faucet is properly resting on the rubber base gasket and does not overlap the rubber base gasket.

CORRECT ✓

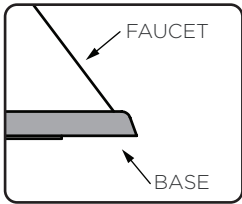

INCORRECT ✗

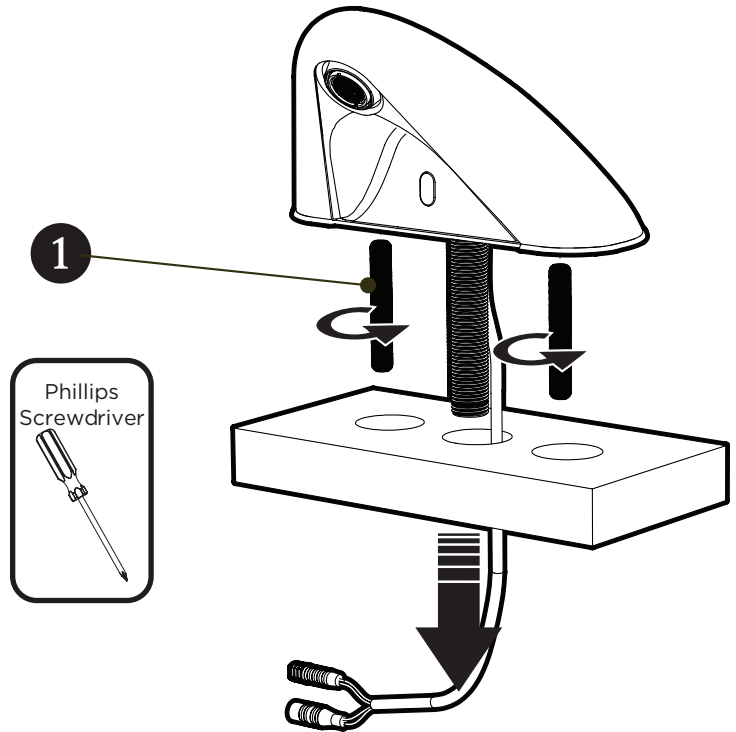
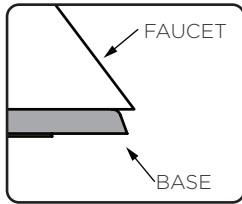

3. From beneath, install Rubber Wire Guard (1) (with notch facing towards rear) over the shank and pass the Sensor wires through the notch to prevent pinching of wires. Install Metal Washer (2) and Mounting Nut (3) onto shank. Hold Faucet in position and wrench tighten Mounting Nut (3). Verify that Sensor wires are not pinched.

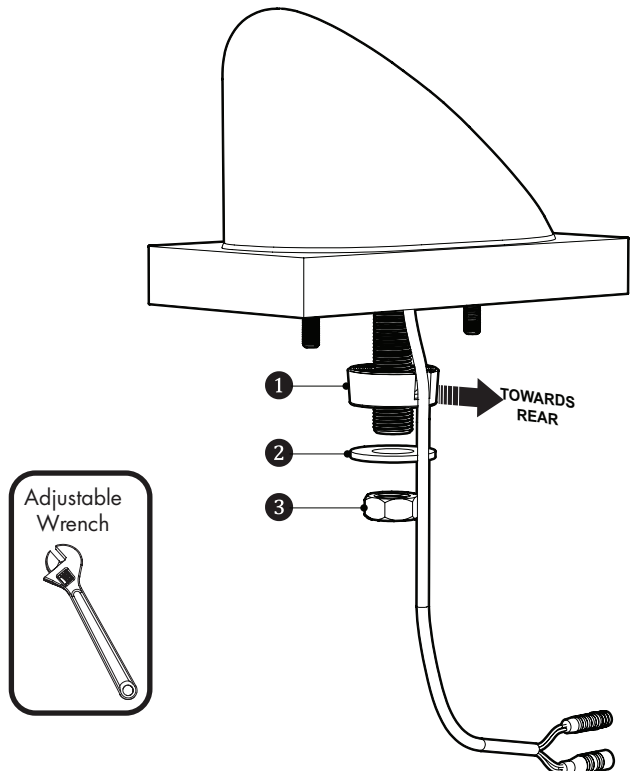

4. From beneath, install “U” Washers (1) onto the Threaded Mounting Posts and secure with the Mounting Nuts (2). Ensure that the “U” Washers (1) are perpendicular to the wall surface for added leverage and wrench-tighten.

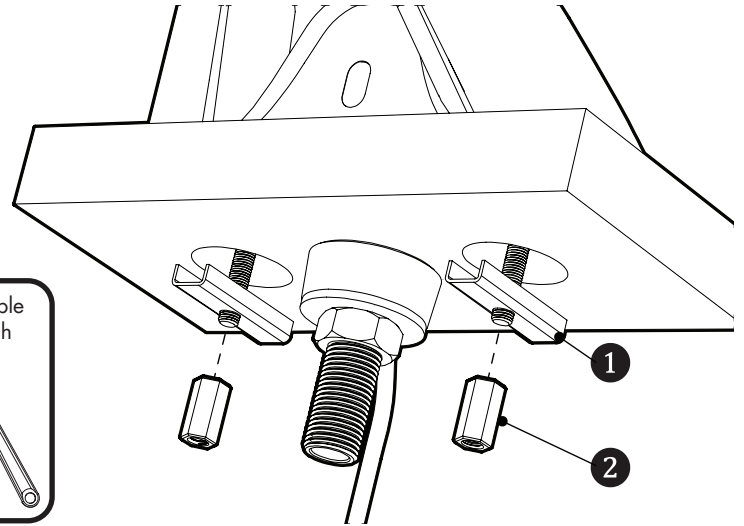
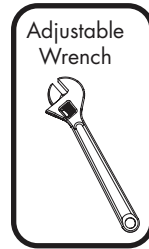

IMPORTANT!

You can mount your Solenoid Box directly to the shank of the Faucet or use the included Flex Hose and secure the Solenoid Box onto the wall for more flexibility. Either of the connection methods will have no impact on the performance of the SF400.

- For **Direct Connection**, please refer to **Option 1 (Step 5)**.
- For **Flex Hose Connection**, please refer to **Option 2 (Steps 6-7)**.

Option 1

5. Thread the Solenoid Outlet directly onto the Shank (1) by hand. Hold Faucet in position and wrench-tighten the connection.

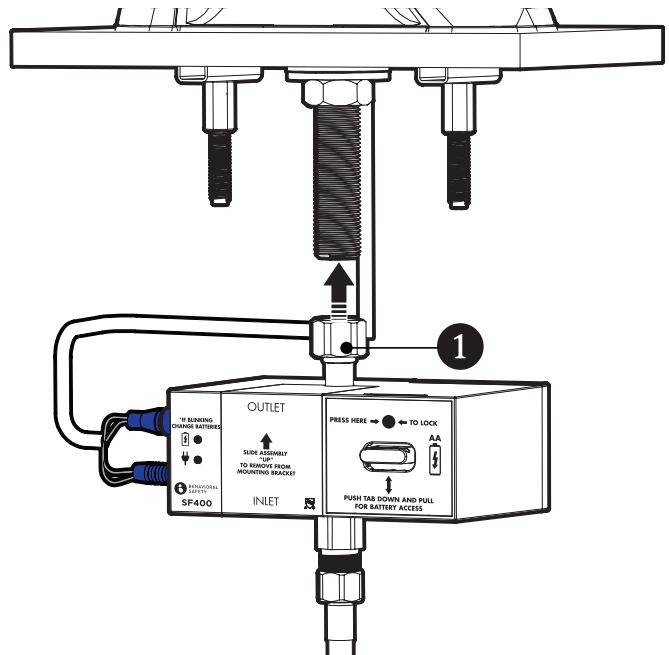
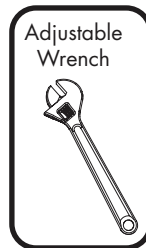

Option 2

6. Should additional space be needed, thread the included Solenoid Hose (2) (marked with GREEN label) to Inlet Shank (1) by hand. Hold Faucet in position and wrench-tighten the connection.

DRY CONNECTION ONLY! DO NOT USE ANY SEALANT ON THIS CONNECTION.

7. Install remaining end of Hose (1) to the "OUTLET" connection (2) of Solenoid. Wrench tighten.

DRY CONNECTION ONLY! DO NOT USE ANY SEALANT ON THIS CONNECTION.

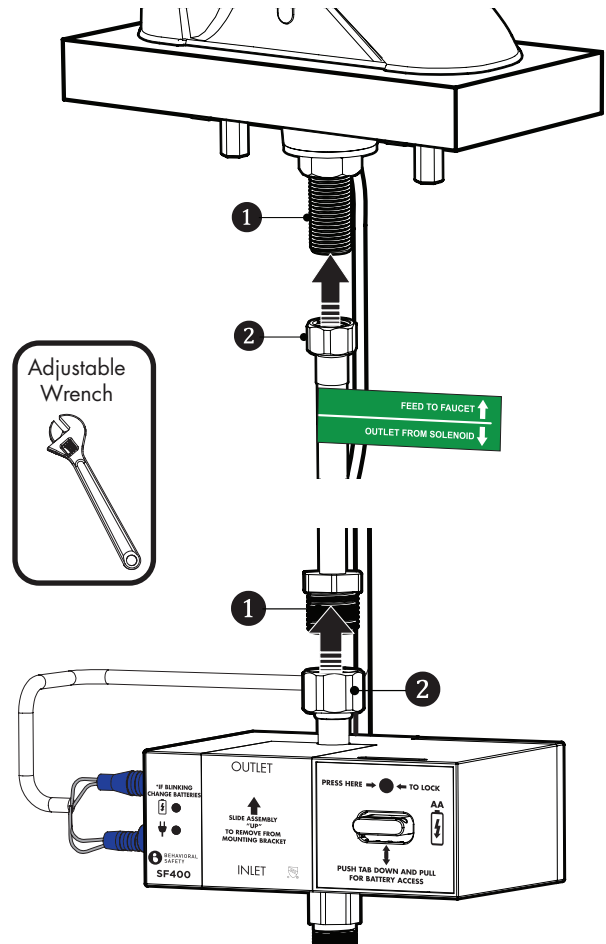

8. Place the Solenoid Assembly against the desired mounting surface while ensuring adequate clearance for servicing of all connections. If using the optional A/C Adapter (not supplied), consider the distance to the nearest electrical outlet. Solenoid Assembly should be mounted so the inlet and outlet ports are aligned vertically. Mark location of Solenoid Assembly on the mounting surface using a pencil.

IMPORTANT! When a P-Trap Cover is being used, ensure that the Solenoid Assembly fits within the P-Trap Cover when mounted. Verify that all hoses are free from bends or kinks.

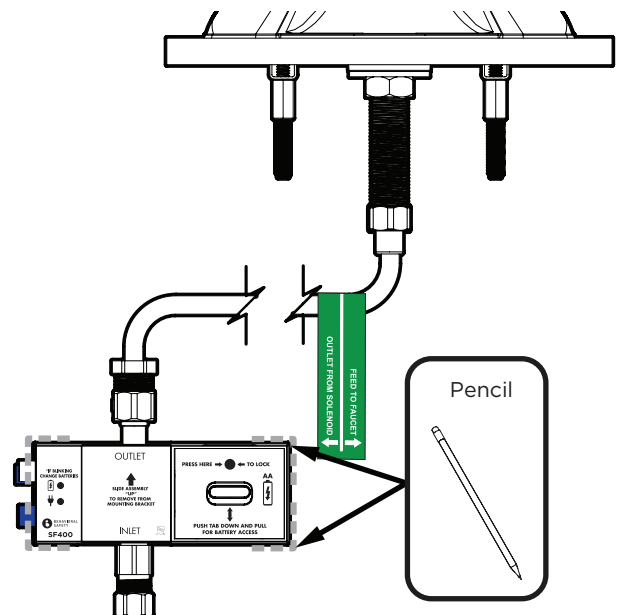

9. Make water connections between the Shut Off Valves and the Under Counter Mixer (UCM) using 3/8" Compression style hoses (not included). Ensure that the COLD supply hose is connected to the "C" port on the UCM, and the HOT supply hose is connected to the "H" port. Wrench-tighten connections. Take care to not over tighten connections or damage may occur.

DRY CONNECTION ONLY! DO NOT USE ANY SEALANT ON THIS CONNECTION.

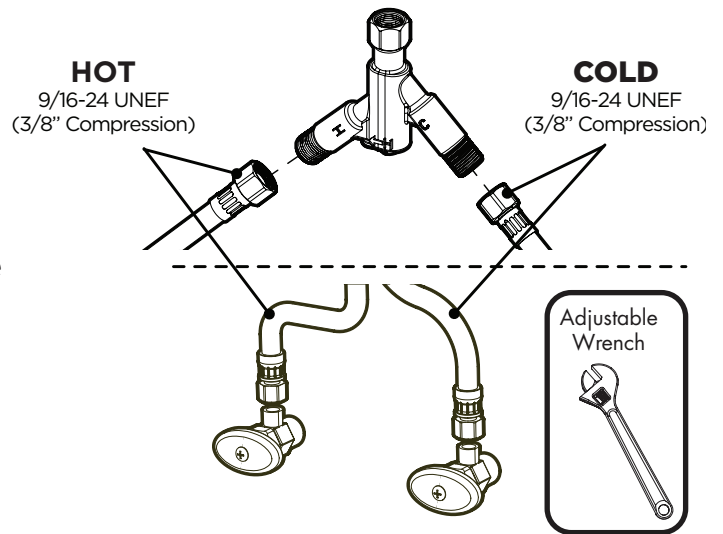

10. Thread the Under Counter Mixer (UCM) to the male connection of the 12in flex hose (marked with Yellow label). Position inlets of UCM so they are accessible. Connect remaining end of YELLOW labeled hose to the Inlet of the Solenoid. Wrench tighten connections. Take care to not over tighten connections or damage may occur.

DRY CONNECTION ONLY! DO NOT USE ANY SEALANT ON THIS CONNECTION.

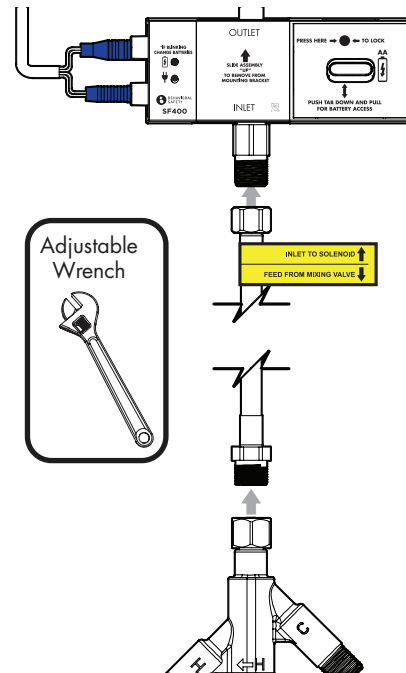

11. Remove Mounting Bracket (1) from Solenoid Assembly. Using the previously marked location on mounting surface, align Mounting Bracket (1) horizontally to approximate position and mark the mounting locations with a pencil. If mounting on drywall and not to stud, use the appropriate anchors and fasteners for application. Recommend screw in easy anchor or equal for drywall.

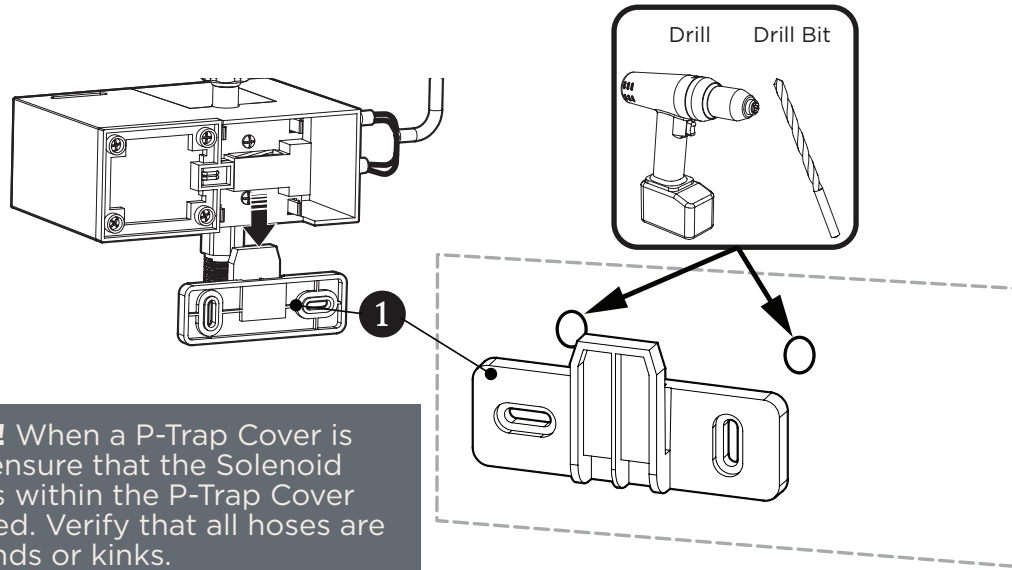

IMPORTANT! When a P-Trap Cover is being used, ensure that the Solenoid Assembly fits within the P-Trap Cover when mounted. Verify that all hoses are free from bends or kinks.

12. After securing the Bracket to the mounting surface, align and slide Solenoid Assembly over Mounting Bracket.

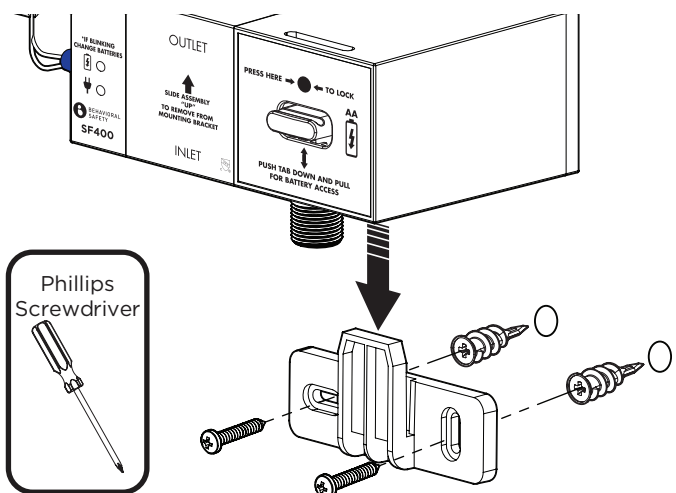

Electrical Connections

13. Make electrical connections from the Sensor Eye to the Solenoid Assembly. Connect the Blue Male Ended Wire to the Female Connection. Connect the Blue Female Ended Wire to the Male Connection. To further aid proper alignment, there are white alignment lines on the connector ends. These alignment lines should face forward when properly installed.

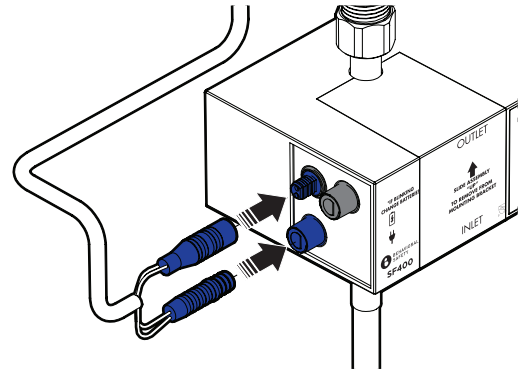

14. Access the interior Battery Enclosure by pressing down on the tab to release the tray holding the batteries (1). Pull out battery tray (2). Insert or replace the batteries with six (6) new standard 1.5v AA batteries. Ensure the position of the new batteries are aligned to the plus (+) and minus (-) symbols within the battery holder.

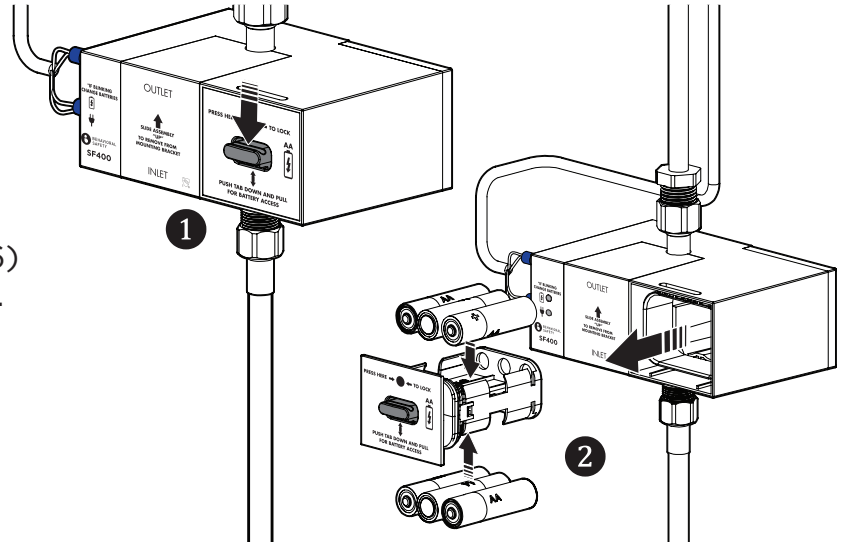

15. Reinstall the Battery Enclosure to the Solenoid Body (1). Make sure to press the indicated location until the battery door is fully seated and locks into position (2).

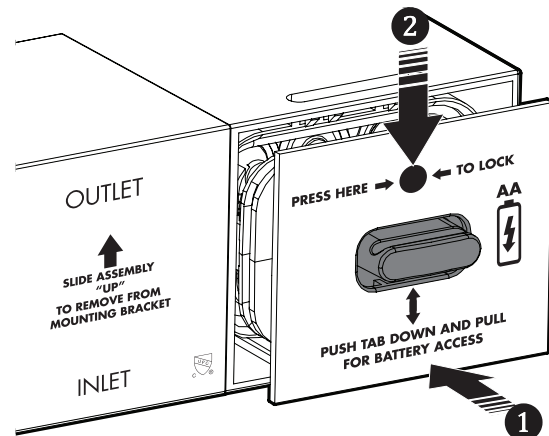

Conversion to A/C Power

1. If you wish to change your Faucet to A/C power, remove batteries from enclosure as shown.

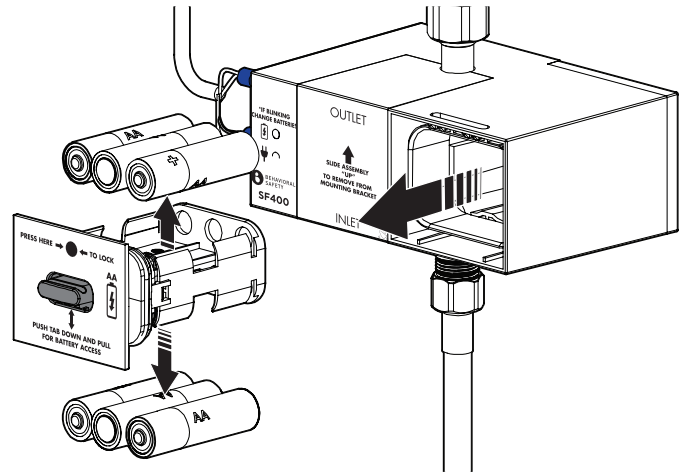

2. Reinstall the Battery Enclosure to the Solenoid Body (1). Connect the A/C Adapter to the Solenoid Body (2). Plug the A/C Adapter into the wall outlet. The A/C light (3) should illuminate.

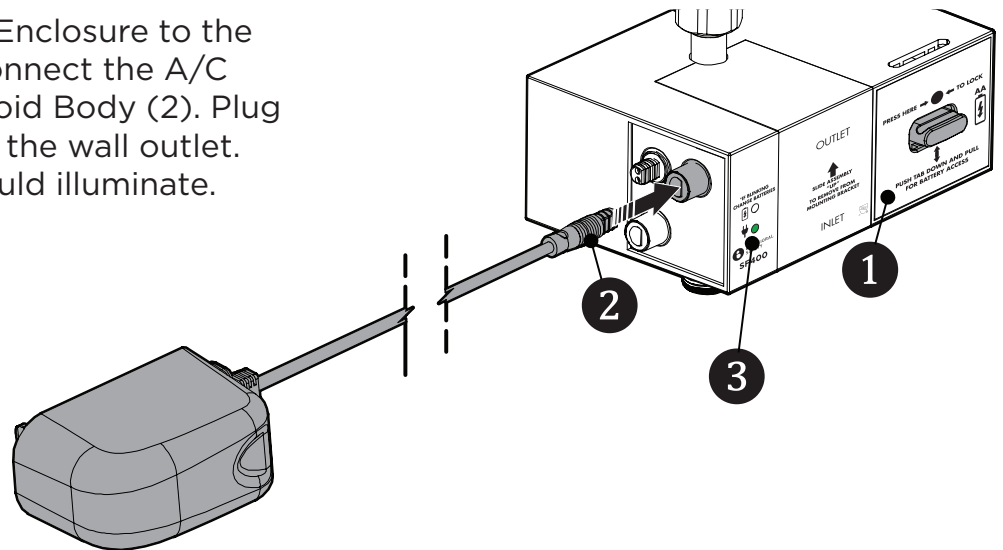

Temperature Adjustment and Flushing

1. Turn on water supplies and check for leaks. Activate Sensor and allow Faucet to run for 1 minute to flush out any debris. Adjust the outlet water temperature by rotating the adjustment screw on the Under Counter Mixer (UCM).

NOTE If the temperature is still too cold after adjustment, switch the HOT and COLD lines on the mixer.

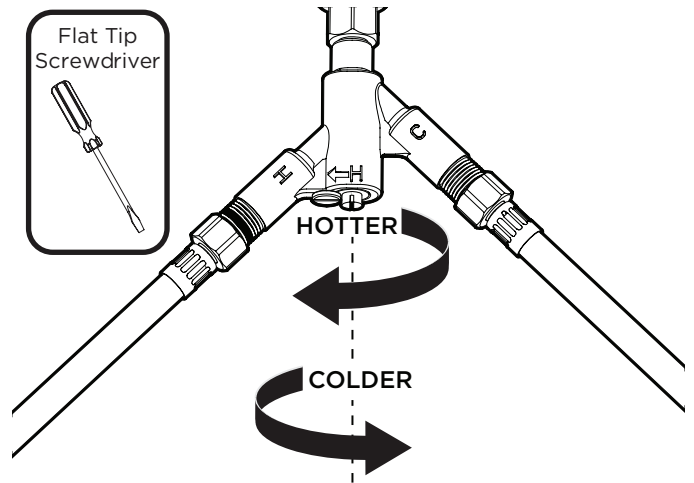

2. Install the Vandal-Resistant Laminar Flow Outlet to the Faucet using the included Aerator Wrench.

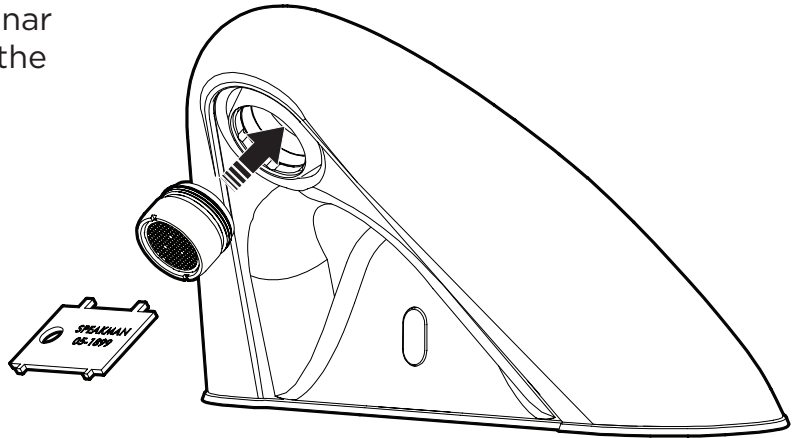
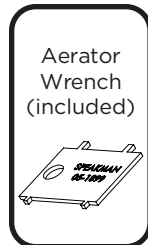

Repair / Replacement Parts

Item	Part No.	Description
1	RPG05-0851-PC	13/16 - 1.5 GPM Laminar Outlet repair group
2	RPG05-0792-PC	13/16 - 2.2 GPM Laminar Outlet repair group
3	A-ELF	13/16 - 1.2 GPM Laminar Outlet repair group
4	A-EA12	13/16 - 1.2 GPM Aerator Assembly
5	RPG38-0128-PC	13/16 - 0.5 GPM Boca repair group
6	RPG76-107258	Laser Sensor Module
7	RPG76-108469	Solenoid Assembly with Battery Pack
8	RPG76-107259	A/C Conversion Kit (120VAC to 6VDC)
9	G05-0650	Low Profile Spout Mounting Parts
10	G66-0193	Mounting Hardware Group
11	RPG20-2024-CA	Under Counter Mixer
12*	SF372	Thermostatic Mixing Valve

NOTE: ITEM MARKED * NOT SHOWN

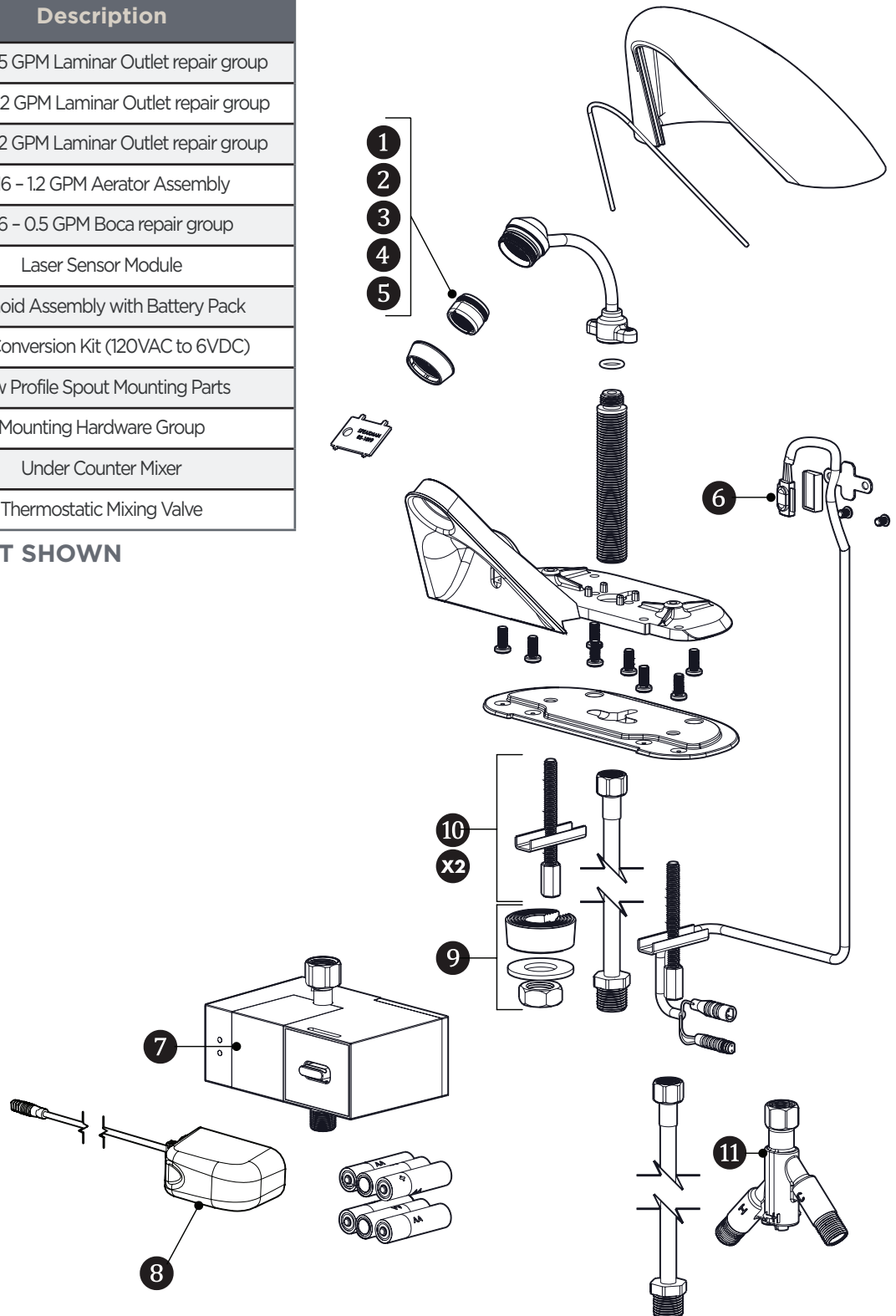

Troubleshooting

BEFORE CALLING BEHAVIORAL SAFETY PRODUCTS FOR SERVICE,
PLEASE RUN THROUGH THE FOLLOWING CHECKLIST:

If water flow from the Faucet decreases

1. Make sure the supply stops are open.
2. Ensure the Temperature Adjuster of the Under Counter Mixer (UCM) is not in the closed position (to open, screw out the Temperature Adjuster Screw (counter-clockwise direction).
3. Check that the In-line Filter located in the hose connecting the solenoid and the mixer is not blocked with debris. Remove filter from the Solenoid Inlet and rinse filter screen with clean water. Reassemble the filter, open stops, and check water flow. Stops must be turned off when filter is removed.
4. Remove the Laminar Flow Outlet from the spout using the outlet wrench. Operate the Faucet with outlet device removed. If water flow is acceptable, disassemble the outlet device and rinse components with clean water.
5. If the above steps do not resolve the problem; call Behavioral Safety Products (706-705-1500) for assistance.

If no water flows from the Faucet, and If you can hear a clicking sound of Solenoid opening, but no water flows

1. Verify that the HOT and COLD wall stops are completely open.
2. If the Battery Light within the Sensor Eye or Solenoid blinks continuously, even when the Faucet is not in use, the batteries within the Solenoid have low voltage and need replacement.
3. Verify that the In-Line Filter in the Solenoid is not blocked by debris. Clean filter if needed.

If you do not hear a clicking sound of Solenoid opening and no water flows

1. If the Battery Light within the Sensor Eye blinks continuously, even when the Faucet is not in use, the batteries within the Solenoid have low voltage and need replacement.
2. Unplug connections to Solenoid for 2 minutes. Plug connections back in. The red light on the Sensor should turn on for several seconds before becoming operational. If not, check power supplies and connections.
3. Disconnect the existing Solenoid Assembly and connect a new Solenoid Assembly. Activate the Sensor and check for water flow. If the water flows, the existing Solenoid Assembly should be replaced.

If the batteries have been replaced, but the Faucet still does not operate

1. Check the battery polarity and electrical connections. Make sure all electrical connections are fully inserted.
2. If the Faucet does not operate, replace the existing Solenoid Assembly with one you know to be functioning

If the Faucet activates, but the water will not shut off

1. Hold a hand in front of the Sensor at up to 7" away for more than 1 minute until the water flow stops. Once the water stops, remove your hand and wait 60 seconds. Then place your hand in front of the Sensor and verify that it is operating properly.
2. If the Faucet still does not shut off, cover the front of the sink with a towel. This will eliminate the potential of reflections activating the Sensor.
3. If it is a new installation and still not working, replace the Solenoid Assembly.

Questions and Answers

Q. How does the Sensorflo® Faucet work?

A. It uses laser technology. The Sensor emits a non-visible beam of light. When an object enters the detection area, the Sensor signals the Solenoid Valve to open for water to flow. When an object leaves the detection area, the Sensor signals the valve to close.

Q. Is the Sensorflo® Faucet sensor beam adjustable?

A. No, the Sensorflo® Faucet sensor beam is not adjustable. It has been factory set to factory specifications for these Faucets.

Q. What about water conservation?

A. The Sensorflo® design directly addresses water conservation. Water savings of up to 85% are not unusual. Additional energy savings are realized by conserving hot water.

Q. Can the water temperature of the Sensorflo® Faucet be adjusted?

A. Yes, this Faucet has a hot and cold water mechanical mixing valve. If you need to meet ASSE 1070, you must use our TMV (Thermostatic Mixing Valve) option.

Q. Does Sensorflo® reduce maintenance?

A. By elimination of on/off handles, control components are reduced and fittings stay cleaner longer. Only a light rinsing and wiping is required to restore the beauty of the Sensorflo® Faucets. Drip stains are eliminated. Fingerprints and soap spots on sinks and fittings are avoided. Finishes last longer and wash areas stay cleaner. Germs and bacteria are not transferred as easily making for a healthier environment.

Q. The chrome finish on my Faucet seems to be deteriorating. What can I do to prevent this from happening?

A. Many commercial cleaning products contain harsh chemicals and abrasives. These products should not be used on any chrome-plated plumbing products. Please use only mild soap and water to clean the Faucet. Dry immediately with a soft cloth.

Q. Does the Sensorflo® system shut off immediately when an object leaves the sensing area?

A. A very short delay of approximately 0 to 1.5 seconds occurs before water is shut off.

Q. Is there a way to adjust the flow of water?

A. The temperature adjusters can be used to control the flow of water.

Q. Is my Faucet protected from power surges?

A. Yes, Sensorflo® has been designed to have built-in power surge protection.

Q. If we lose power, do I have to do something to get the Faucet to operate again?

A. After a power outage, the Faucet is automatically ready for operation as soon as the power comes back on.

Q. If I call a plumber to come and install this Faucet, will they know enough to hook it up?

A. Our installation diagrams are very easy to follow.